

承认书

APPROVAL SHEET

客户 CUSTOMER:

产品类别 PRODUCT SERIET:

产品型号 MODEL NO. :WH148-1B-2-B100K-L15-18T

常州永久电子科技有限公司

CHANGZHOU PERPETUAL ELECTRONIC TECHNOLOGY CO.,LTD.

公司地址：江苏省常州市礼嘉镇
LiJiang Town Changzhou Jiangsu China
Tel:0086-51988061162
Fax:0086-519-88061162
E-mail:fanny@china-potentiometer.com
Http://www.china-potentiometer.com

1. ELECTRICAL CHARACTERISTICS 电气特性

Item	Item 項目	Specification 規格
1.1	Resistance value and tolerance of resistance 阻值及容许偏差	B100K±20%
1.2	Load power 负载功率	0.125 W
1.3	Rotational noise 旋转杂音	47mV max
1.4	Insulation Resistance 绝缘电阻	>100MΩ At 200V DC
1.5	Withstanding Voltage 耐电压	>1Minute At 250V AC
1.6	Max rated voltage 最大工作电压	50V AC
1.7	Tracking error 双联同步误差	0~40dB±3 dB
1.8	Residual resistance 残留阻抗	R1,2<10Ω ; R2,3<10Ω
1.9	Switch contact resistance 开关接触阻抗	
1.10	Switch power 开关电力	

2. MECHANICAL CHARACTERISTICS 机械特性

2.1	Dimensions 外形尺寸	Refer to the separate product drawing
2.2	Total rotation angle 全回转角度	300±5°
2.3	Rotational Torque 旋转力矩	20~200gf.cm
2.4	Switch working angle 开关动作角度	
2.5	Switch torque 开关力矩	
2.6	Shaft Push& Pull Strength 轴推拉强度	≤8kgf
2.7	Click slip-out force 定位点起动力	
2.8	Shaft Wobble (mm p-p)轴摆动	≤0.3mm
2.9	Shaft Stop Strength 止挡强度	<5kg.cm

3. DURABILITY CHARACTERISTICS 耐久特性

3.1	Rotating life 旋转寿命	10,000 cycles
3.2	Storage Temperature Range 储藏温度范围	-30℃~+80℃
3.3	Operation Temperature Range 使用温度范围	-20℃~+70℃
3.4	Soldering Heat Characteristic 耐焊锡热	260° C/2.5±0.5S

CHANGZHOU PERPETUAL ELECTRONIC TECHNOLOGY CO.,LTD.				LOT.NO 样板编号	
				MODER. 型号	WH148-1B-2-18T
DWN 拟制	DHK 审核	APPO 批准	DATE 日期	DESCRIP ON 描述	Rotary carbon potentiometer 旋转式碳膜电位器
				20161117	

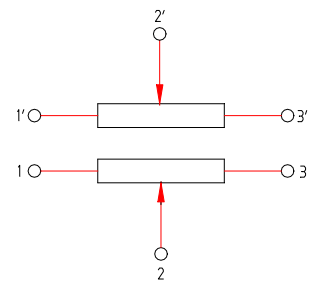
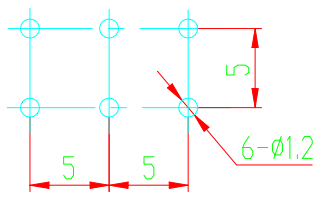
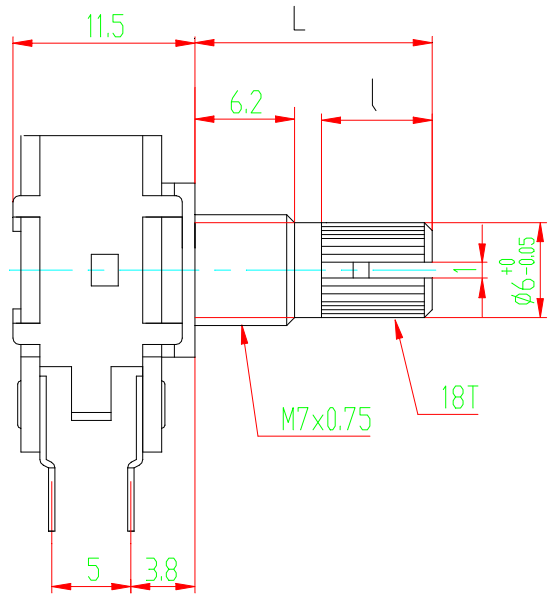
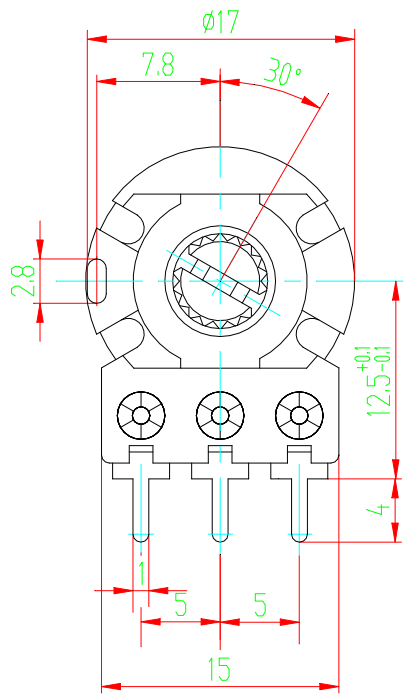

L	15	20	25
l	7	12	12

2				5		
1				4		
	DATE	REVISION	APPROVED	3		
			MODER:	WH148-1B-2-L15-18T		DRAWING NO:
			常州永久电子科技有限公司			
DWN	DHKD	APPD				